

Calibration services

Key to reliable,
accurate results



SARC

MARITIME SOFTWARE AND SERVICES

CALIBRATION SERVICES

Maintain the high-quality standard of your instruments and have confidence in their measurement accuracy with the SARC service programs. Make sure that the cornerstone of your Inclination experiments is in excellent shape.

EXCHANGE SERVICE

With the Exchange Service¹, you save money and time, without losing deplorability of your sensor.

How does it work? SARC keeps an eye on the validity date of the calibration certificate, we send you an exchange sensor that is fully refurbished and certified. Upon arrival, you can replace the sensor. Afterwards you replaced the new calibrated sensor you ship the original sensor back to us.

EXCHANGE SUBSCRIPTION

We offer an exchange subscription contract for a period 5 years.²

Main advantages

- Full warranty on the exchange sensor during the entire subscription period.³
- An attractive discount when compared to the single exchange price.
- We take care of your planning. Based on the calibration date of the sensor, we will send you the sensor in time for each scheduled exchange. Once you receive the sensor you know it is time to replace/exchange your sensor.

SINGLE EXCHANGE AS NEEDED

You can also order a single, one-time exchange when you need it.^{4,5}



STANDARD SERVICE

When you choose our Standard service, you send the sensor to SARC in Bussum, the Netherlands. After receiving the sensor, we service and calibrate the sensor and ship it back to you.

THE SARC STANDARD SERVICE CONSISTS OF:

- Inspection
- Cleaning
- Re-calibration

Main advantages

- Fixed planning for service: every 12 months you will get an automatic reminder.

SINGLE CALIBRATION AS NEEDED

You order a single, standard service when you need it.⁴

THE BEST OPTION FOR YOU

For your easy decision making, here is a concise overview of the Service Programs.

	Exchange service	Standard service
Procedure	Calibrated exchange sensor will be shipped to customer first.	Sensor will be send to SARC. After recalibration, it will be shipped back.
Downtime	Negligible	Can be up to 7 weeks
Re-calibration	NA	Included
Repairs included (normal wear and tear)	NA	Included
Warranty extension	12 months	-
Subscription	5 years	-
Your benefits	Guaranteed reliable results	



PENDULUM

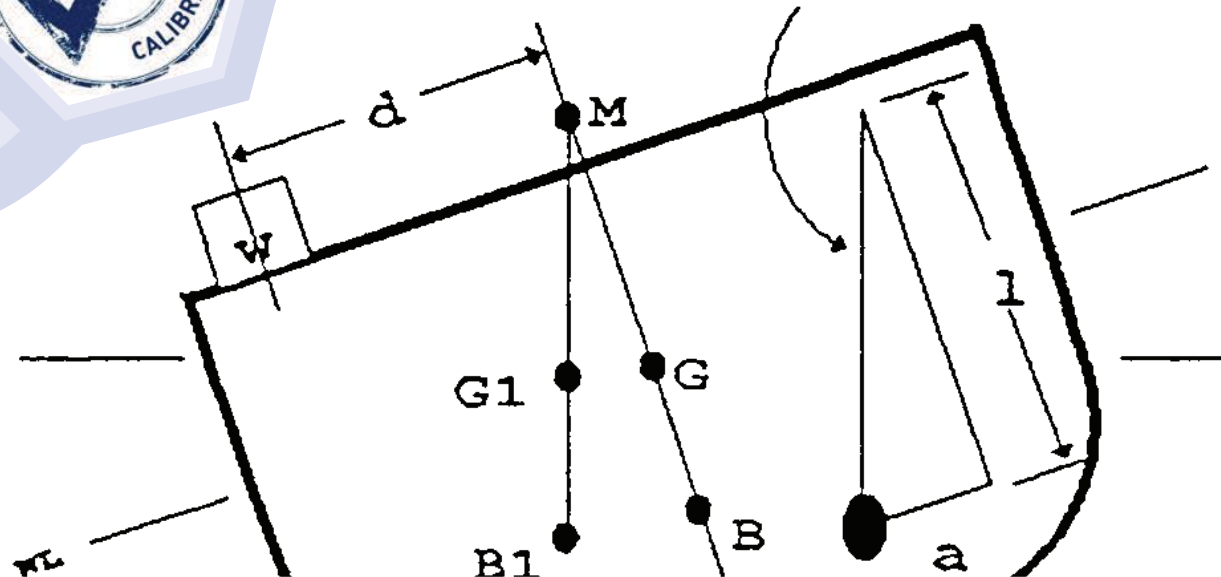

¹The Exchange service only pertains to the sensor itself. Converter hardware and other accessories are not included in the Exchange service, as they do not need recalibration.

²The subscription will automatically renewed with 1 year unless you unsubscribe after the period of 5 years.

³A life time warranty during the exchange subscription is based on a recalibration period of 12 months.

⁴Additional costs may apply to products which have not been maintained for over 24 months.

⁵Certificate expiration may differ with this option. Please contact us in advance.

WHY CALIBRATION?

You have chosen the SARC inclining sensor to obtain reliable, objective and traceable measurement results. Reliable measurement data is key to making the right calculations. Since sensors and electronics may drift, might get polluted or mechanically wear out, it is important to maintain and calibrate your sensor using a reliable, traceable reference standard.

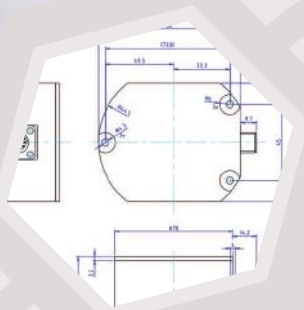
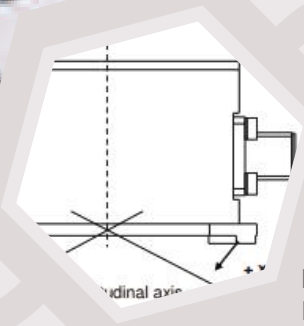

For most instruments the recommended re-calibration interval is annually. The best interval is dependent on the application, the intensity of use, and process parameters, etc. For example:

LEGISLATION / CERTIFICATION

If you are using the sensor for class witnessed inclining experiments, it is mandatory to have a calibrated sensor including a calibrated report. The calibration report does not contain an expiry date. However, Class societies expect a calibration report not older than 12 months.

PROFESSIONALITY

Professional Naval Architects need equipment that is maintained, calibrated and in excellent condition. Your customers must have confidence in your results, which should be traceable to National respectively International Standards.

INCIDENTS

For example, if a sensor is exposed to physical conditions which are out of the specifications, the internal sensor could be damaged. Unless you do a calibration check after an incident, you will not know for sure that the sensor is working correctly.

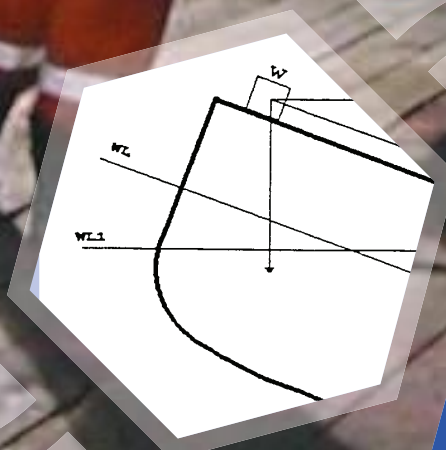

SARC
MARITIME SOFTWARE AND SERVICES

ADDRESS
Brinklaan 109 A11
1404 GA Bussum
The Netherlands

PHONE
+31 85 040 90 40

MAIL
sarc@sarc.nl

WEBSITE
www.sarc.nl